

CARL HANSEN & SØN

THE SPHERICAL BED AND THE ENGLISH CHAIR

BY KAARE KLINT





LINKS TO MATERIAL

[PRESS RELEASE](#)

[DESIGNER PROFILE](#)

[LIFESTYLE IMAGES](#)

[CRAFTSMANSHIP IMAGES](#)

[LINE DRAWINGS](#)

[COMPANY PROFILE](#)

KAARE KLINT

THE SPHERICAL BED AND THE ENGLISH CHAIR

Kaare Klint (1888-1954) is known for his unique understanding of design and proportions, making the materials appear as the main decorative elements and his Spherical Bed and The English Chair are not exceptions. The English Chair and Spherical Bed are the most time-consuming and complex designs in Carl Hansen & Son's collection, and they are crafted according to the finest cabinetmaking techniques by the skilled master cabinetmakers and apprentices at THE LAB, Carl Hansen & Son's in-house apprentice workshop at the company's furniture factory on Funen in Denmark.

The English Chair was first presented at the Cabinetmakers' Autumn Exhibition in Copenhagen in 1931, and Klint was inspired by old English Chairs from the 18th century. Klint has masterfully used wood as a decorative element by incorporating it as a contrasting material. The back, sides and seat are made of French canework, and it takes a skilled weaver almost a week to complete just one chair.

Kaare Klint's Spherical Bed was presented in 1938 at the Cabinetmakers' Autumn Exhibition and has since been hailed a mathematical stroke of genius, as all the dimensions are unbelievably precise. The bed's complex design and superior craftsmanship are time-consuming, and it takes a full month just to complete one bed.





THE SPHERICAL BED

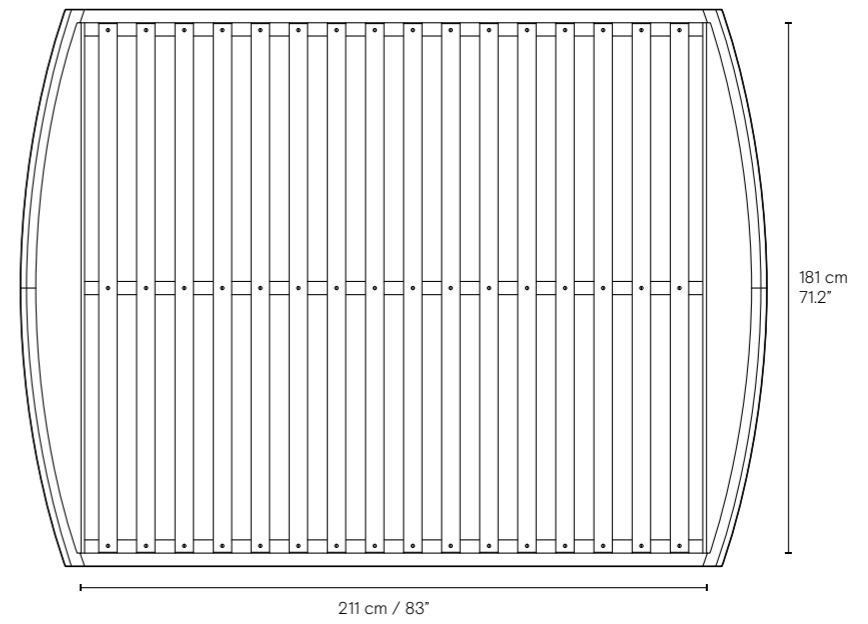
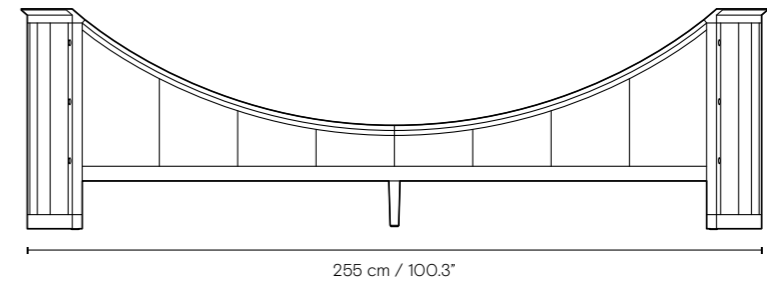
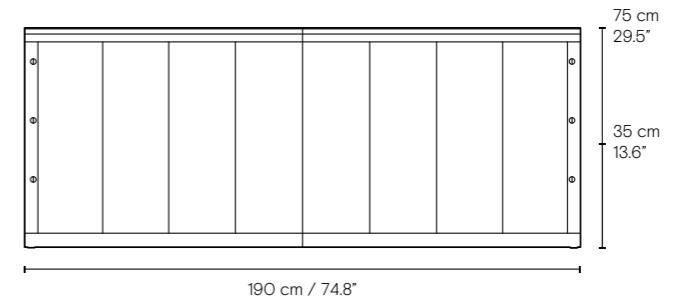



THE ENGLISH CHAIR

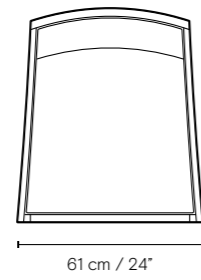
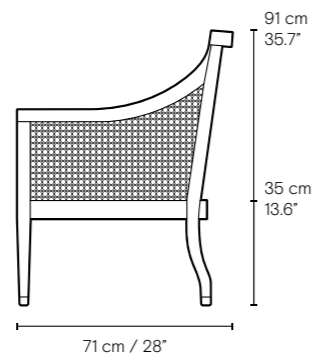
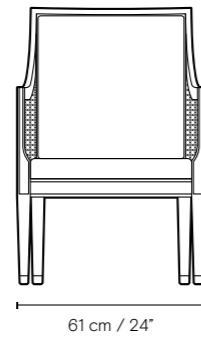



KAARE KLINT
1888–1954

One of the most revered founding fathers of Danish furniture design, Kaare Klint influenced several generations of Danish furniture designers with his mathematically-based functionalism. He exerted his influence not only as a visionary educator, but also through several distinctive furniture works that collectively became the paragon of functionalist design.

Klint is regarded as a reformer whose approach to architecture and design broke radically with the traditional period- and style-focused teaching of the day, focusing instead on the hands-on, practical study of architecture and furniture design. As a pioneer of functionalism, Klint emphasized the study of proportions, studying the dimensions of the human body and focusing on furniture's practical purpose. In this respect, he was part of a renaissance in Danish furniture design, developing furniture that first and foremost served its primary intention. Throughout his career, Klint insisted on clear and logical design, clean lines, the highest-quality materials, and superb craftsmanship.

One of Klint's greatest strengths was his unique sense of proportion and spatial awareness. He firmly believed that furniture should suit and conform to its user, and based his classic designs on careful study of the human body, originating the concept of 'human furniture'.





BY APPOINTMENT TO
THE ROYAL DANISH COURT

CARL HANSEN & SØN

